

# CE-1250B Install Guide

## Included Items:

- Pole Mount for LCD/PVM x 1
- M4x10 VESA screws x 4
- 13/14mm Wrench x 1
- 6mm Allen Wrench x 1

**CAUTION:** This mount is intended for use only with the maximum weights indicated. Use with products heavier than the maximum weights indicated may result in instability causing possible injury. This product is intended to mount to round pole/pipe with a diameter from 1-3/16" to 2-1/8."

**⚠ Maximum Load Capacity: 22 lbs / 10 kgs ⚠**

## 1. Disassemble Mounting Clamp

Using the supplied Allen wrench remove the 2 Allen bolts on the back-side of the mounting clamp.

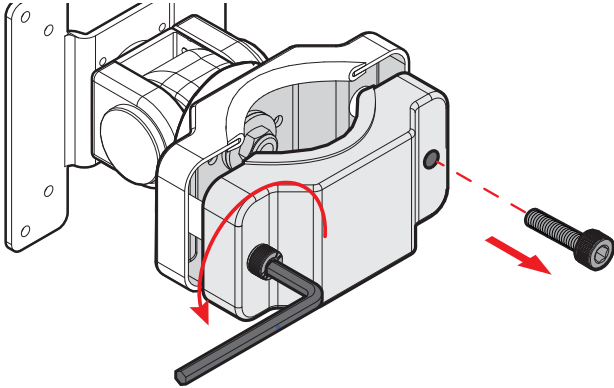

## 2: Mounting to VERTICAL Pole/Pipe

While holding the arm and clamp portion of the bracket, insert the Allen bolts into the clamp and tighten using the supplied Allen wrench. If mounting to horizontal pole see details at bottom of page.

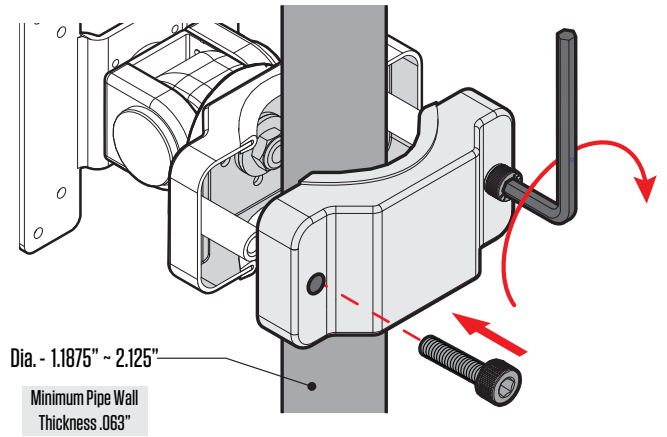

## 3. Attach Monitor

Attach your display to the VESA plate on the pole/pipe mount using the 4 supplied M4x10 screws. Use either VESA 75mm or 100mm pattern.

**MAX Load:  
22 lbs / 10 kg**

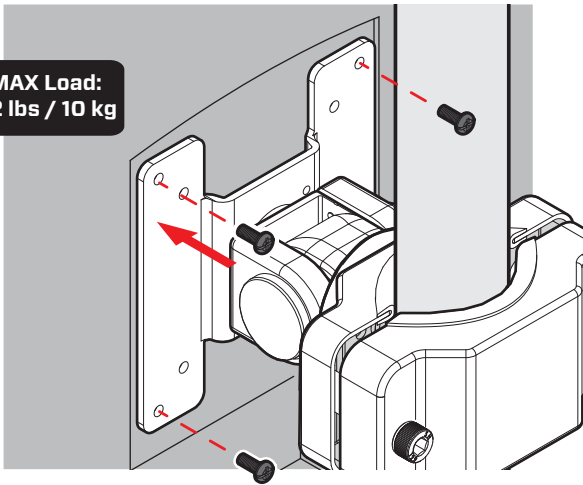

## 4: Adjust Monitor Angle

Remove the plastic adjustment cap as shown below to access the adjustment nut. Adjust the viewing angle using the included 14mm wrench.

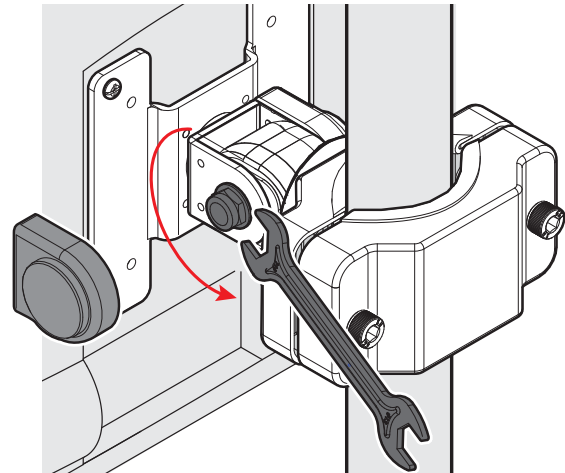

## OPTION: Mounting to HORIZONTAL Pole/Pipe.

### 1. Rotate Clamp

With the back-side of the clamp removed (Step 1); remove the Phillips head screws inside the base of the arm portion of the bracket. Then, rotate the clamp portion 90° until the screw holes in the base line up.

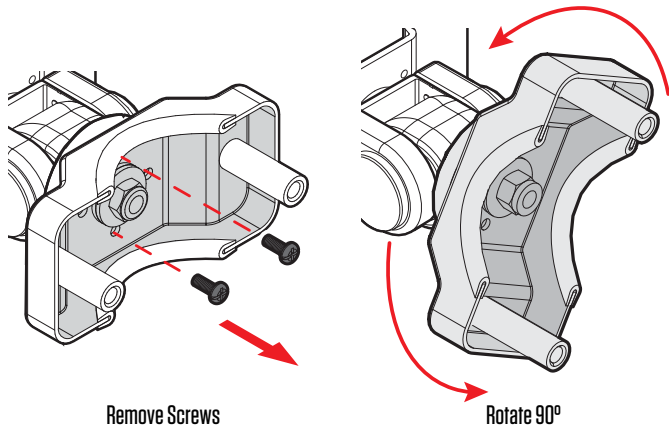

### 2. Attach

With the clamp rotated; re-insert the Phillips head screws. Then attach to horizontal pole/pipe using the supplied Allen wrench.

