

CE-CG2X2.5

Suspended Ceiling Mount Tile & 5ft Pole Kit



Maximum Load Capacity: 35 lbs / 16 kgs



KEY FEATURES:

Designed to install into standard 2' x 2' drop ceilings, the CE-CG2x2.5 can mount nearly any LCD or PVM monitor up to 35 lbs. Height adjustments can be made by raising or lowering the pole and securing it into place with the included locking collar. The tile and pole kit contains all necessary hardware for installation.

- Recommended for LCD or PVM up to 35 lbs
- Installs into Suspended T-Rail Ceilings
- Adjustable Height from 10" to 4' 5" from Ceiling
- Adjustable Tilt and Swivel
- Powder-Coated Aluminum 2' x 2' Ceiling Tile Plate
- Painted Pole Hides & Protects Cables
- Mounting Hardware, Safety Cables & Adjustable Turnbuckles Included
- VESA 75 & 100
- UL Listed

GENERAL	
Material	Tile: Steel / Pole: Aluminum
Dimensions (tile)	23.75" x 23.75" x 3.51" / 60.32cm x 60.32cm x 8.94cm
Dimensions (pole)	1.6" (Dia) x 4' 10.875" (L) / 41.5mm (Dia) x 1.49m
Weight	20 lbs / 9.071kg

DIMENSIONS:

Unit : Inches

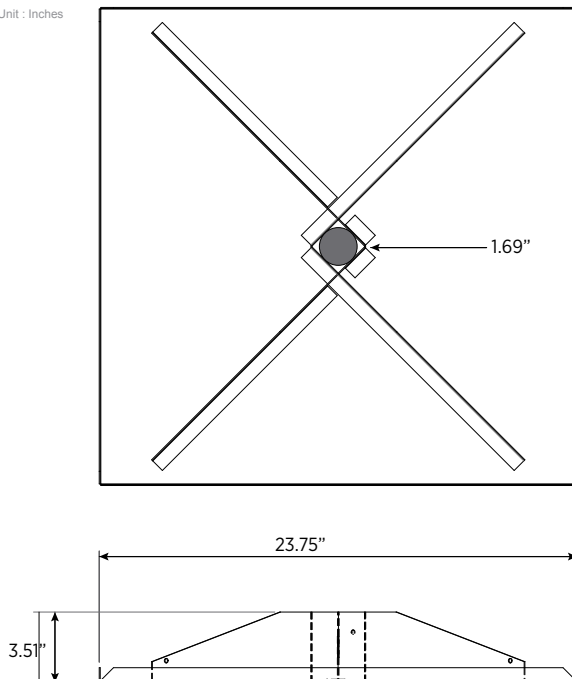

DIAGRAM:

