

CE-CG2x2HD

Suspended Ceiling Tile Mount for Heavy Duty Telescoping Monitor Poles – Tile Only, No Pole



Maximum Load Capacity: 60 lbs / 27 kgs



KEY FEATURES:

- Designed to accept all Clinton Heavy Duty Telescoping Monitor Poles
- Powder-Coated Welded Aluminum 2' x 2' Ceiling Plate
- Installs into Suspended T-Rail Ceilings
- Safety Cables with Adjustable Turnbuckles Included

**Telescoping Monitor Pole Sold Separately*

SPECIFICATIONS	
Dimensions (L x W x H)	23.75" x 23.75" x 3.51" / 60.32cm x 60.32cm x 8.94cm
Weight (Tile Only)	8.3 lbs / 3.76kg

HEAVY DUTY TELESCOPING POLE OPTIONS	
CE-CMHL-3	Adjustable from 3' 2" to 5' 7" - White
CE-CMHL-3B	Adjustable from 3' 2" to 5' 7" - Black
CE-CMHL-6	Adjustable from 6' 2" to 11' 5" - White
CE-CMHL-6B	Adjustable from 6' 2" to 11' 5" - Black

DIMENSIONS:

Unit : Inches

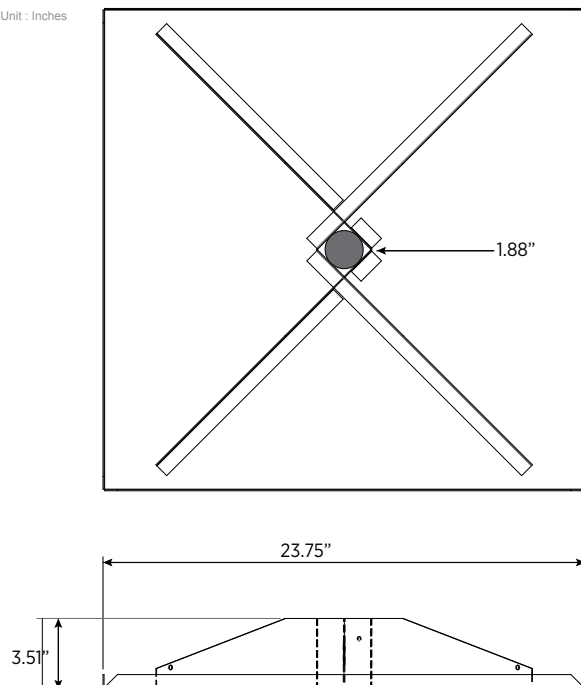

DIAGRAM:

