

CE-IDXWB(B) IDX Series Camera Wall Bracket

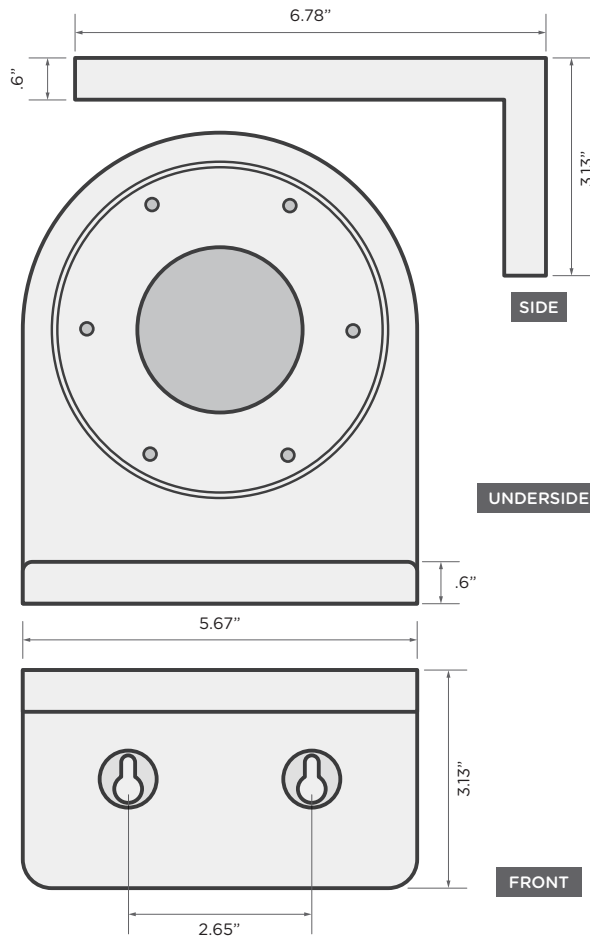

*Camera Shown Not Included

DIMENSIONS:



INFO:

- Compatible with all Clinton IDX Indoor Dome Cameras
- Easy to Install
- Includes Mounting Screws
- Removable top cover plate for access to camera connections

CE-IDXWB for White IDX Series Cameras

CE-IDXWBB for Black IDX Series Cameras

SPECIFICATIONS:

Materials	Plastic
Dimensions	6.78" (L) x 3.13" (H) x 5.67" (W) 172.21mm (L) x 79.5mm (H) x 144.01mm (W)
Weight	0.4 lb / 0.18 kg

ASSEMBLY:

