

## M13VG288IR Tamron CS Mount Lens



### INFO:

- 2.8-8mm (2.8x)
- Supports Up to 3 Megapixels
- F1.2 - T360 (Equivalent to F360)
- Auto Iris (DC Type)
- Day/Night & IR
- Manual Focus
- CS-Mount

### DIMENSIONS:

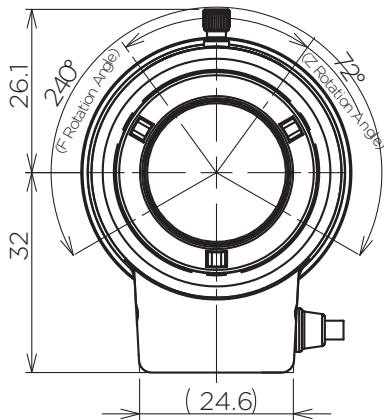

Unit : mm

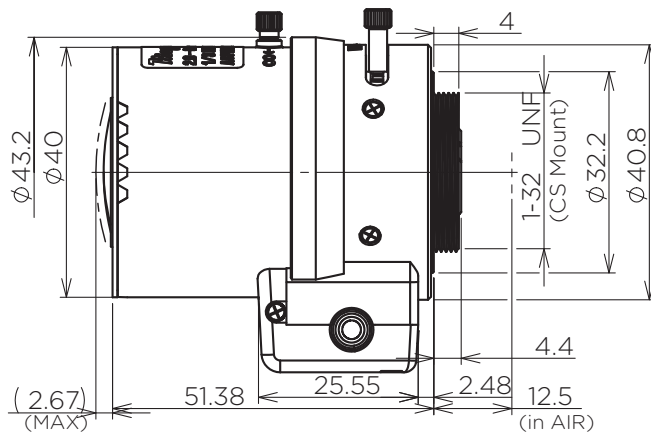

### SPECIFICATIONS:

Focal Length	2.8-8mm (2.8x)
Iris Range	F1.2 - T360 (Equivalent to F360)
Iris Operation	Auto, DC Type
Focus Operation	Manual
Zoom Operation	Manual
Mounting Type	CS Mount, Metal
Focusing Range	$\infty$ - 0.3m
Back Focus Distance (in air)	8.339 - 14.944mm
Operating Voltage	Open: 4V / Close: .7V
Operating Temperature	-4°F - 140°F / -20°C - 60°C
Weight	.15 lbs / 70g
<b>1/3" Angle of View</b>	
Wide	100.1° x 72.9°
Tele	35.8° x 26.8°
<b>1/4" Angle of View</b>	
Wide	72.9° x 53.9°
Tele	26.8° x 20.1°