

YV3.3x15HR4A-SA2L Fujinon CS Mount Lens



INFO:

- 15-50mm (3.3x)
- Supports Up to 1.3 Megapixels
- F1.5 - T360 (Equivalent to F360)
- Auto Iris (DC Type)
- Day/Night
- Manual Focus
- CS-Mount

DIMENSIONS:

Unit : mm

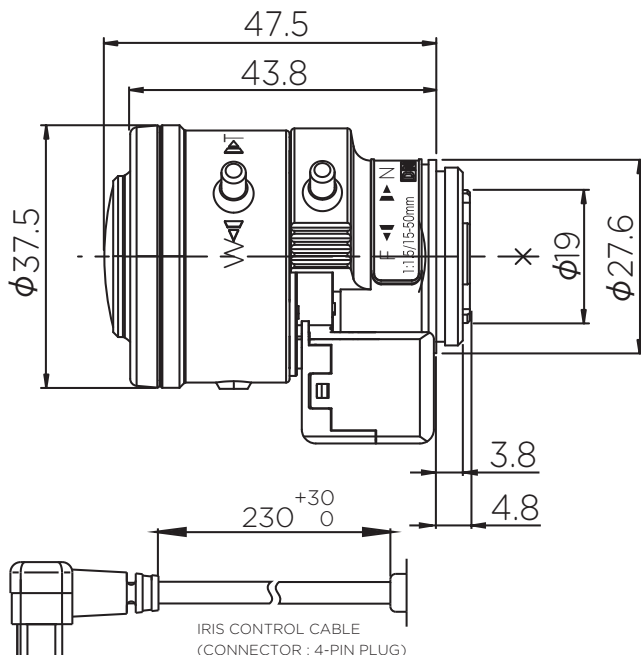
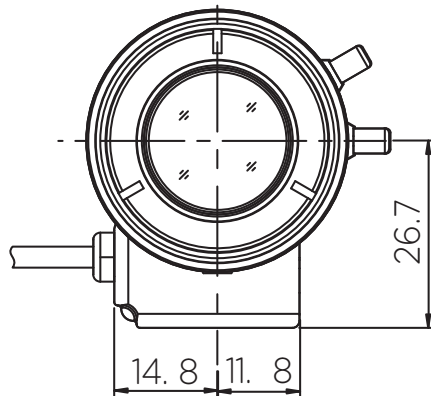

SPECIFICATIONS:

Focal Length	15 mm - 50 mm (3.3x)
Iris Range	F1.5 - T360 (Equivalent to F360)
Iris Operation	Auto, DC Type
Focus Operation	Manual
Zoom Operation	Manual
Mounting Type	CS Mount, Metal
Focusing Range	∞ - 0.8m
Back Focus Distance (in air)	8.56mm
Operating Voltage	23 mA (Max.) @ DC 4V
Operating Temperature	-4°F - 140°F / -20°C - 60°C
Weight	.11 lbs / 50g
1/3" Angle of View	
Wide	18.29° × 13.45°
Tele	5.29° × 4.09°
1/4" Angle of View	
Wide	13.45° × 10.16°
Tele	4.09° × 3.08°