

CE-1290W

WALL MOUNT INSTALLATION GUIDE

Included Items:

- Pole Mount for LCD/PVM x 1
- Allen Wrench x 1
- Display VESA screws x 4
- 13-14mm Wrench x 1



CAUTION: This mount is intended for use only with the maximum weights indicated. Use with products heavier than the maximum weights indicated may result in instability causing possible injury. This product is intended to mount to pole/pipe with a diameter from 1.18" to 2.0"



Maximum Load Capacity: 22 lbs / 10 kg



Disassemble Mounting Clamp

Using the supplied Allen wrench remove the 2 Allen bolts on the back-side of the mounting clamp.

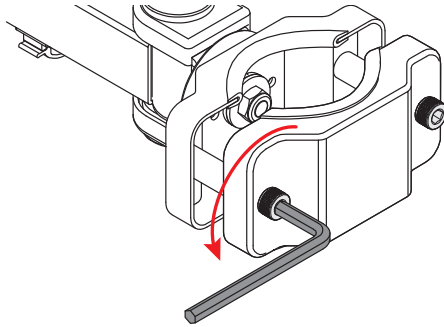

Option 1: Mounting to VERTICAL Pole/Pipe.

While holding the arm and clamp portion of the bracket, insert the Allen bolts into the clamp and tighten using the supplied Allen wrench. Proceed to Step 1 & 2.

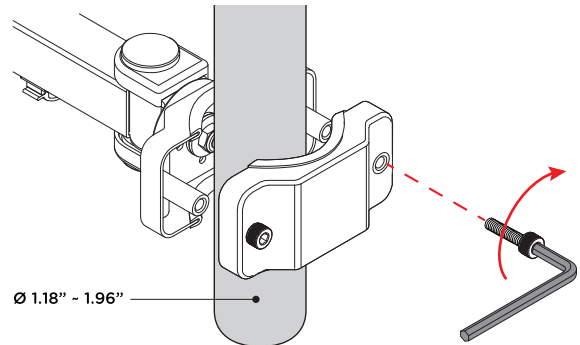

Option 2: Mounting to HORIZONTAL Pole/Pipe.

Remove the Phillips head screws inside the base of the arm portion of the bracket.

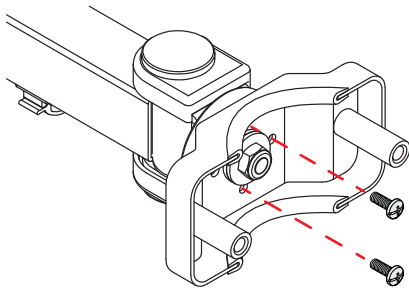

Rotate the clamp half 90° until the screw holes in the base line up.

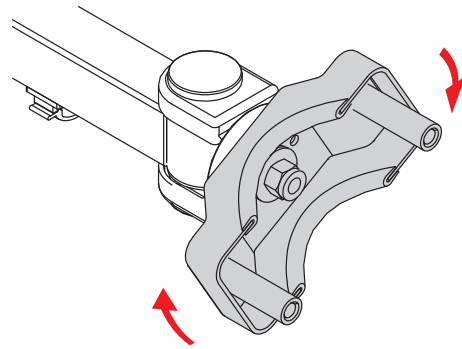

With the clamp rotated; re-insert the Phillips head screws.

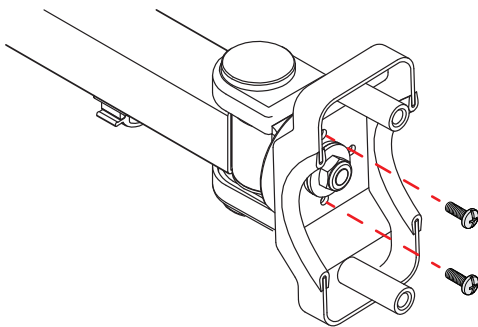

While holding the arm and clamp portion of the bracket, insert the Allen bolts into the clamp and tighten using the supplied Allen wrench. Proceed to Step 1 & 2.

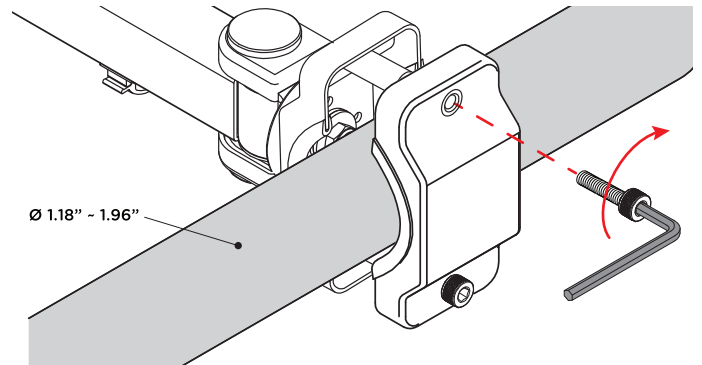

1. Mounting Display

Attach your display to the VESA plate on the pole/pipe mount using the 4 supplied VESA screws.

MAX Load:
22 lbs / 10 kg

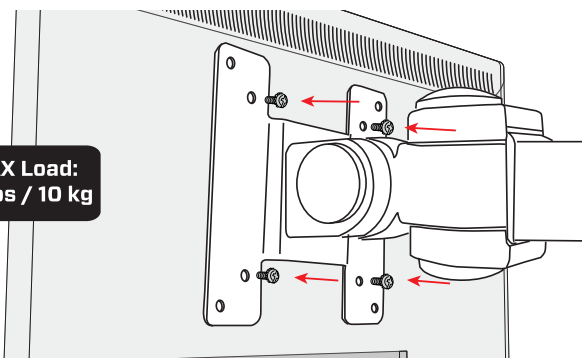

2. Cable Management & Adjustments

Run the power and audio/video cables into the cord management clips. Remove the 3 plastic adjustment caps as shown below to access the three adjustment nuts. Adjust the viewing angle using the included 14mm wrench.

