

Public View
CE-M8S
CE-M10S
User Manual

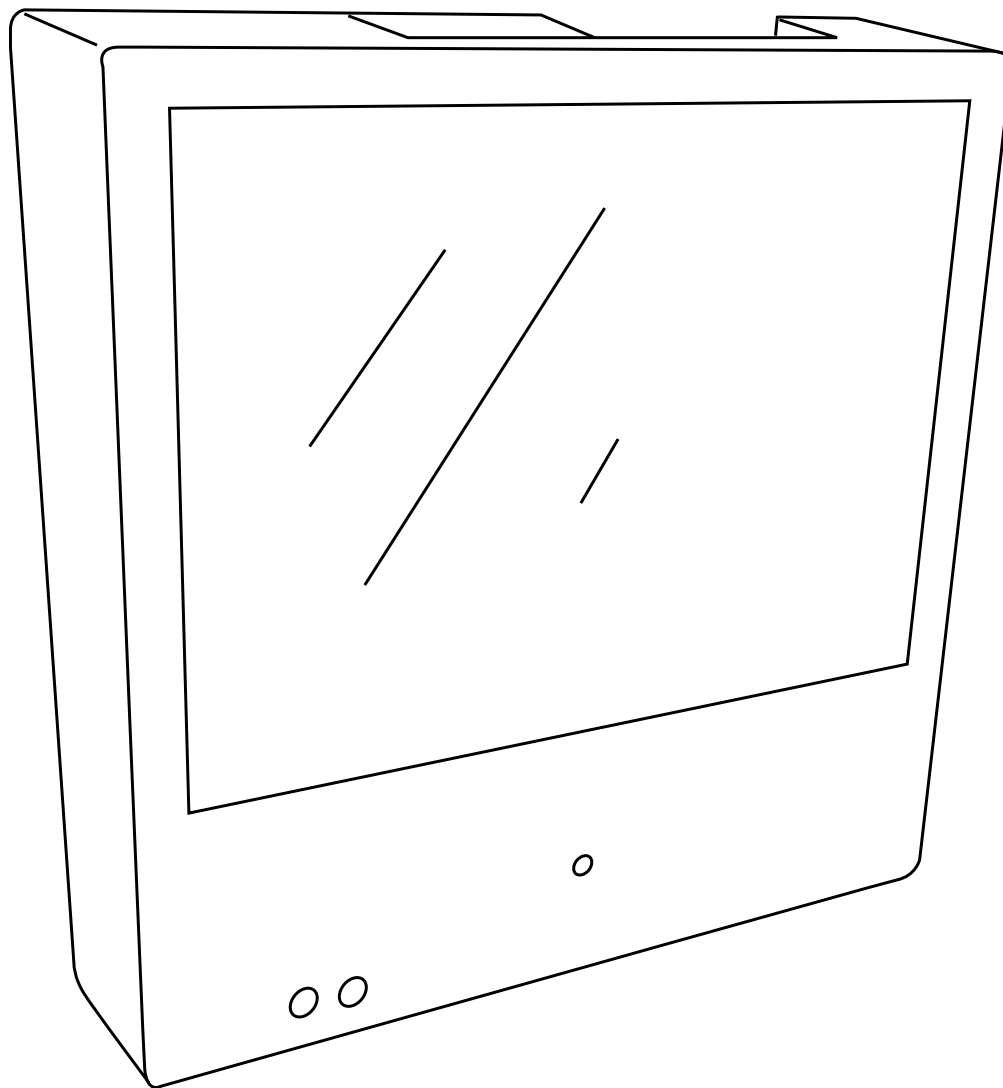

Table of Contents

Introduction	3
Contents, Installation and Set-up	4
Display Functions	5
Remote Control	6
Display Set-up / SD-Card Files	7-8
Camera OSD Menu.....	9
Lens.....	10
Exposure.....	11
White Balance.....	12
SSDR.....	13
BLC, HLC.....	14
HLC.....	15
DNR3.....	16
Day/Night.....	17
Special	
Image Adjust.....	18
Image Adj. (continued), Monitor.....	19
Camera Title.....	20
Sync, Motion Detection.....	21
Motion (continued), Privacy.....	22
Comm Adj. (continued), Language, Return, Exit.....	23
Troubleshooting	24-25

Introduction

Congratulations on the purchase of your new Public View Integrated Camera Security display. This display and camera combination is designed for simple and effective loss prevention by making the viewer aware of video surveillance measures.

Features:



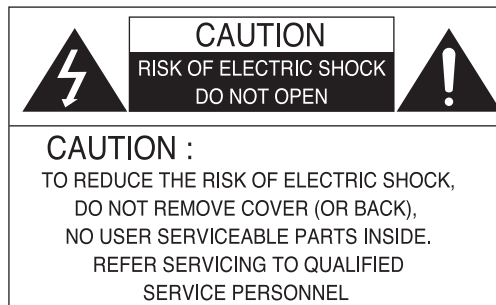

- Rugged Steel Enclosure
- SD-Card Player
- Motion Detection
- Low Voltage power
- Integrated High-Resolution Digital Day & Night Camera (600 TVL)
- VESA mounting pattern for ceiling or wall mount options
- Remote control operation of all screen adjustment features
- Wide viewing angles
- Video Output

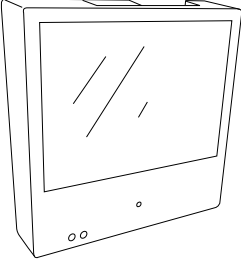

Precautions

- **There are no user serviceable parts inside the unit. Authorized service personnel must perform all service. To avoid electrical shock, do not disassemble the unit. Any attempt to disassemble the unit will void the warranty.**
- **Verify DC power supply before installation. This unit requires an external AC to DC power supply capable of supplying sufficient DC voltage to the display.**
- **Install the monitor in a location that is suitable for the display. Make sure there is adequate ventilation around the unit, and that the display is mounted securely to its support structure.**
- **Do not place the monitor in direct sunlight, or near sources of heat.**
- **Do not place the monitor in a damp area.**
- **Do not place the monitor in an area that is below 40°F.**
- **Clean the monitor with water or non-ammonia glass cleaners only. Do not use abrasive cleaners, abrasives, or highly concentrated ammonia to clean the front of the display. Clean with a damp cloth only, do not spray directly with water.**

PACKAGE CONTENTS

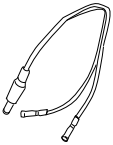
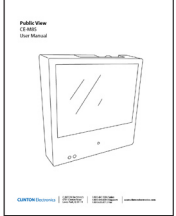
	 			
CE-M8S or CE-M10S with access door and security screw	Security Allen Wrench 2 GB SD Card	Remote Control (batteries included)	Power Pigtail (for Hardwiring)	User Manual

Installation and Set up

Unpacking your display

Your Public View display comes with all of the items shown above. Carefully remove the display from its packing and set the unit on a firm surface. Save the packing in case of future service requirements.

Installation of the display

The display should be located where it will have the most effect on deterring potential shoplifting. Keep in mind the lighting conditions, viewing area, ease of installation, and distance from the power supply when choosing a location. The display is compatible with many available wall and ceiling mounts, consult your dealer for suggestions. The rear of the display has a VESA 75mm & 100mm mounting patterns that accepts M4x8mm screws. Please refer to the installation instructions on the particular mounting bracket and details of how to install.

Connecting the display

This display requires a 24V DC power supply. Locate the applicable AC to DC power supply in a suitable location where there is a power source, and access to run the low voltage cable to the display.

For single unit power supplies, you will need to keep the distance from the power supply to the display less than 75 ft. For multiple unit power supplies, the power supply can be located at further distances from the displays at a central location. Please refer to the specific power supply installation instructions for recommended wire size and distances.

 **Caution: Do not connect the power connector to the display when energized, doing so may damage the electronics inside the display. Connect power supply to unit, then to 120v wall outlet.**

Display Functions

Features

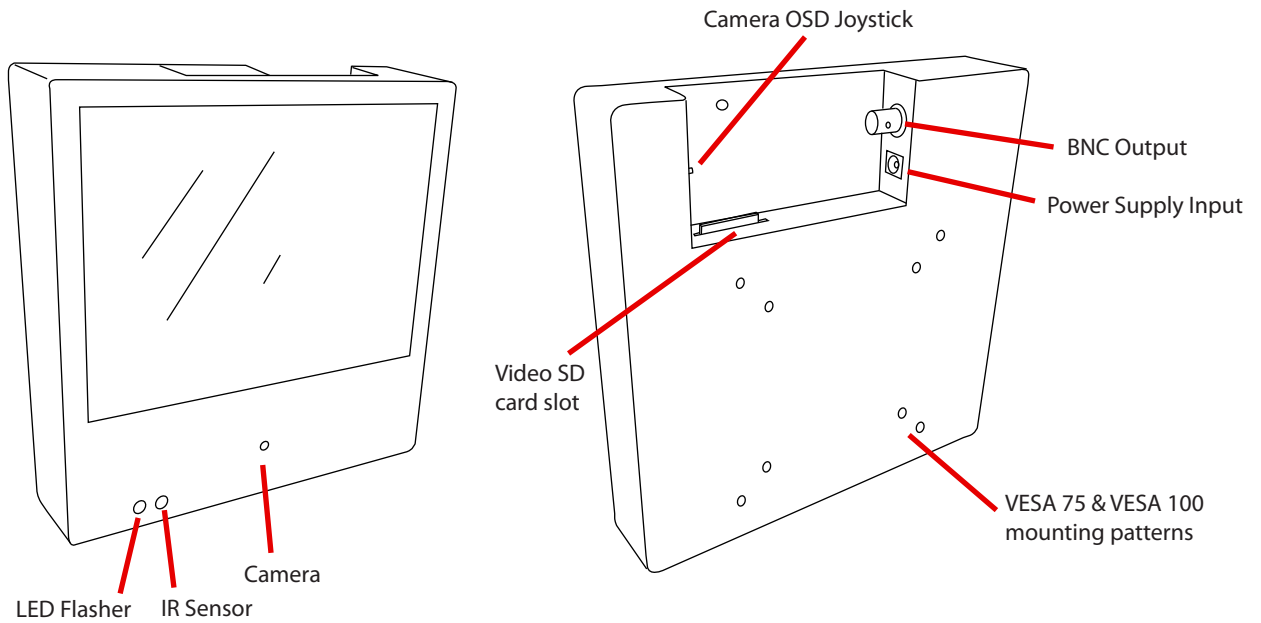

Control Access

The access door for the SD-Card, power, and BNC connections is located at the back of the unit and must be loosened using the included security allen wrench.

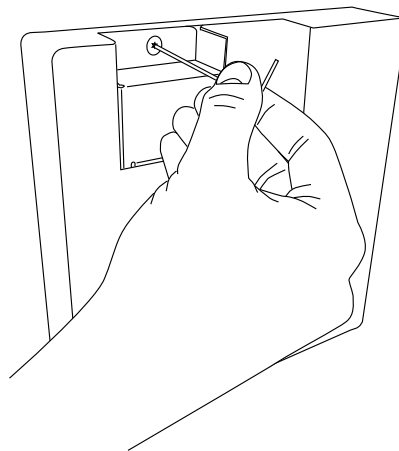

Remote Control

The parameters of the display can be adjusted by using the included remote control.

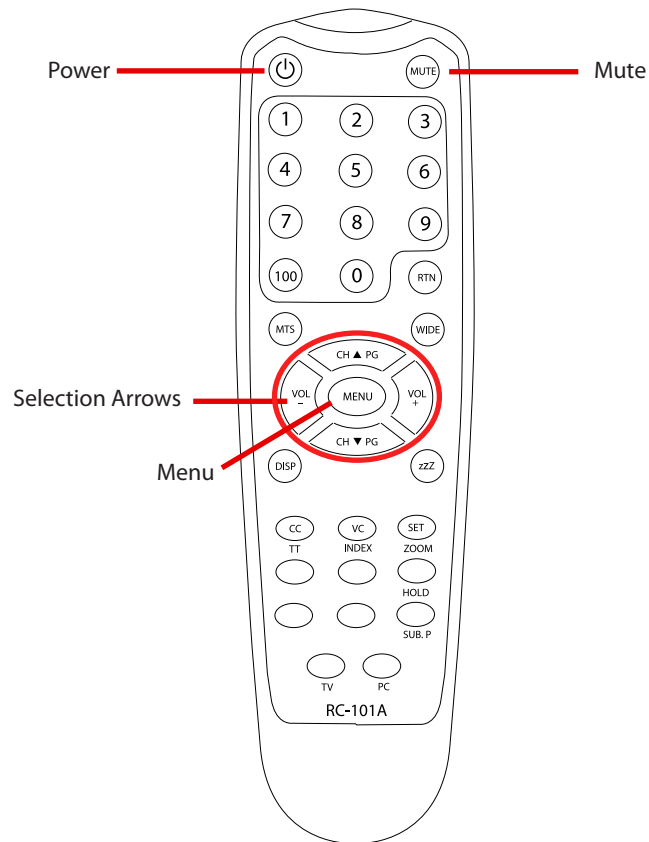

Power – On/Off function. This will power off the display only. The internal camera can still supply video to an external display or DVR.

Mute –Disables the audio on the unit.

Menu – Adjustment of audio, video, signal, tools, & language.

- Push MENU button once.
- Use arrow buttons located around the MENU button to pick category.
- When correct category is chosen, press VOL- and VOL+ buttons to adjust given parameter of display.
- When adjustment of selected parameter is done, press MENU to go back to the previous screen, or simply wait for the menu screen to time out.

Selection Arrows – Use in conjunction with the menu button to navigate and make adjustments.

Display Set-Up

Video Menu: The display should be pre-set for most installations, however if some adjustment is necessary, we suggest you follow these recommendations by pressing the MENU button on the remote control:

1. First adjust the BRIGHTNESS control to set the black level so that the images are at their brightest while the black images are still black. Do not adjust too high where the black portions of the image become gray or the image will have a "washed out" appearance.
2. Set the CONTRAST control to set the white level so that the images are at their brightest without losing definition in the white portions of the image.
3. Adjust the COLOR control to achieve a realistic image of the items within the viewing area.
4. Adjust the TINT control if the image has bluish or reddish tint to the white portions of the image.
5. Decrease the SHARPNESS if the image appears too grainy or pixelated. Increase the SHARPNESS if the image appears too soft.
6. The RESET selection can be used to return the Video settings back to the factory defaults.



Audio Menu

1. The Audio Menu can be used to raise or lower the volume of the chime or SD-Card activated audio. NOTE: The MUTE function on the remote control will disable the audio/chime sound.
2. Select the audio source by selecting CHIME to enable the built in chime sound, or SD-AUDIO for the audio on the SD-Card to play.

Feature Controls Menu

1. The LANGUAGE can be changed to one of the following: English, French, German, Spanish, Italian, Dutch, Greek, Swedish.
2. In the OSD CONTROL menu you can set the horizontal and vertical position of the OSD menu, as well as rotate or mirror the menu, and control the duration the menu is on screen 2-16 seconds.
3. In the IMAGE MODE setting, you can select from one of the following:
 - *NOTE: if an SD-Card is not present the display will show a settings menu. (Motion & SD-Video settings only)
 - Motion: Switches the on-screen image from SD-Card content to camera image upon motion.
 - SD-Video: Displays the SD-Card content only (the camera will still supply footage to an external DVR or display if attached.)
 - Camera: Displays camera image only, regardless of SD-Card presence.
4. In the MESSAGE CONTROL setting, you can turn the message on the bottom of the screen on or off, as well as select the message to read "WELCOME" or "RECORDING IN PROGRESS". You can also control the message to flash on and off, or be steady on. Here you can also disable or enable the flashing LED on the front of the device.

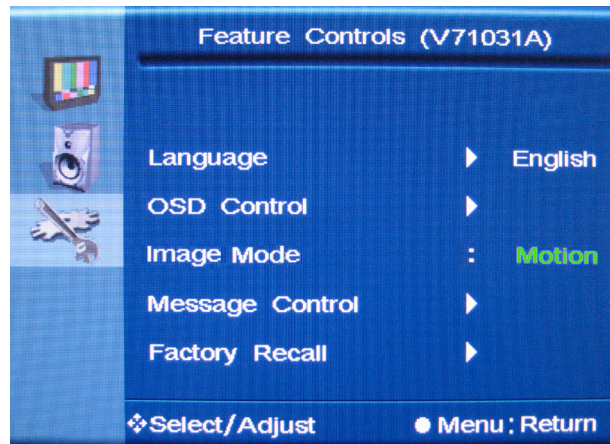

Change SD-Card Image/Video/Audio

- Insert the SD-Card into your computer or SD-Card reader.
 - Move the desired JPEG image, or AVI video file into the SD-Card folder.
- (For the M10S- the required full screen image size is 1024x786)**
(For the M8S the required full screen image size is 800x600)
- Leaving multiple media files on the SD-Card will result in the device cycling through all loaded media.
 - Insert the SD-Card back into the PVM with the contacts facing out, as shown on the right- DO NOT FORCE IT IN.
 - **WHEN SD-CARD IS INSERTED, YOU MUST POWER CYCLE THE UNIT. You can do this by pushing the power button on the remote control, or by unplugging the power cord from the wall.**
 - **An SD-Card MUST be inserted, or you will see a "Settings" Menu.**

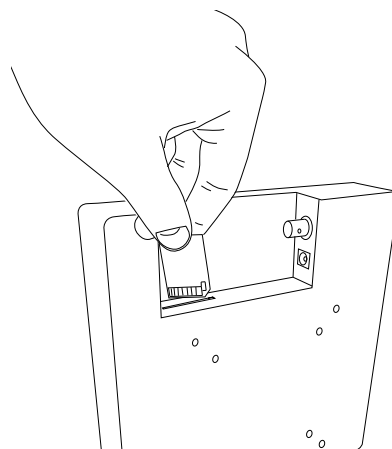

When an SD-Card is inserted, you must power cycle the unit by pushing the power button on the remote, or unplugging the power from the wall.

Camera OSD Menu

Camera functions and settings can be adjusted or changed by activating the OSD menu. When the OSD menu is activated text will display on the monitor. The user can then move the cursor to the desired function to change the setting.

SETUP Menu			
LENS	• DC MANUAL		
EXPOSURE	• BRIGHTNESS • SENS-UP	• SHUTTER • RETURN	• AGC
WHITE BALANCE	• ATW • MANUAL	• OUTDOOR • AWC → SET	• INDOOR
SSDR	• OFF	• ON	
BACKLIGHT	• OFF	• BLC	• HLC
DNR3	• OFF	• ON	
DAY / NIGHT	• AUTO • EXTERN	• COLOR	• B/W
SPECIAL	• IMAGE ADJ. • SYNC • COMM ADJ	• MONITOR • MOTION DET • LANGUAGE	• CAM TITLE • PRIVACY • RETURN
EXIT	• SAVE	• NOT SAVE	• RESET

Accessing the OSD Menu

Settings can be adjusted using the joystick located on the back of the device.

Camera OSD Joystick

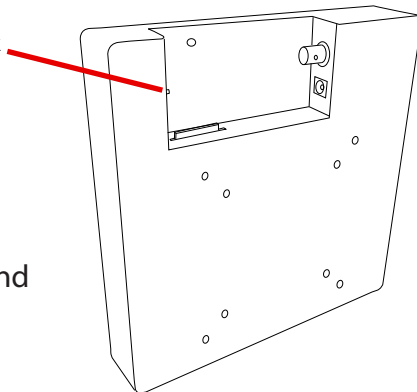

2. Press the SETUP button

- Settings can now be made. The SETUP menu is displayed on the monitor.
- Select a menu function from the list by using the UP and DOWN buttons.
- Position the cursor to the desired function.

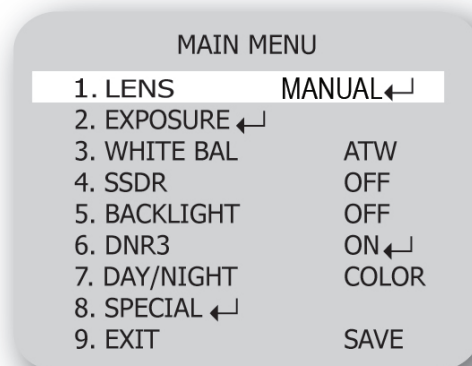

Accessing the OSD Menu

3. Select a menu item from the list available by using the UP and DOWN buttons.

- Functions are selected using up and down buttons.
- Place the cursor over a desired item, the selected position is displayed.

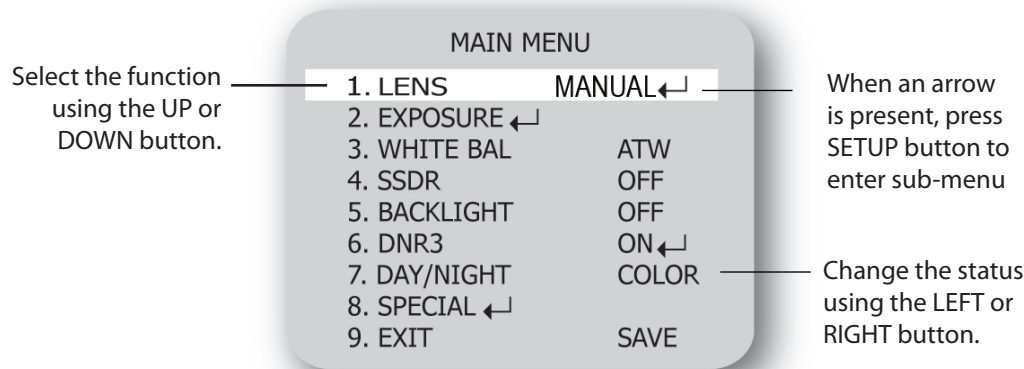

4. Set up a selected item by using the Left and Right buttons.

5. To finish the settings, select 'EXIT' and press the SET button.



Notes

- An item with the ↵ icon also has sub menus. To select a sub menu, select an item with the icon and press the SET button.
- An item with the --- icon has no sub-menus available for selection.

LENS (Adjusting the brightness level)

Using this function, you can control the screen brightness.

1. When the SETUP menu screen is displayed, select 'LENS' by using the Up and Down buttons so that the arrow indicates 'LENS'.

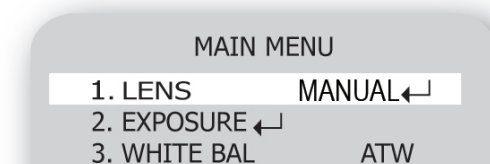

2. Press SETUP to enter the sub menu and adjust the following.

- BRIGHTNESS : Adjusts the video brightness (selectable from 1 - 70).



Notes

- When using an auto iris lens, the setting of the auto iris lens selection switch located on the back of the camera must be on DC or VIDEO depending on the type of lens which is being used. (Refer to the picture on page 8)
- If color rolling occurs when using a DC lens, set Shutter to A.FLK.
- Some lenses may not work properly, depending on the setting of the BRIGHTNESS LEVEL.

Exposure

1. When the SETUP menu is displayed, select 'EXPOSURE' by using the Up and Down buttons so that the arrow indicates 'EXPOSURE'. Press SETUP to enter.
2. Select the desired mode using Up and Down buttons.

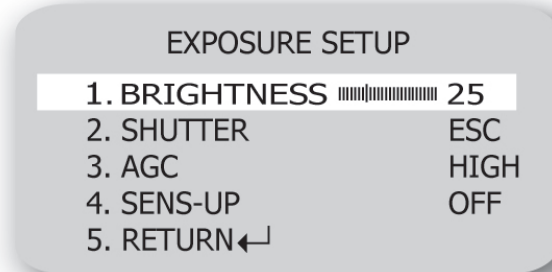
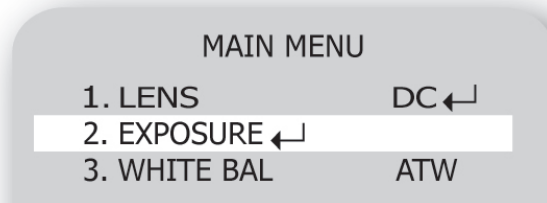

BRIGHTNESS: Adjusts the exposure brightness

SHUTTER: You can select either auto or manual shutter.

- A.FLK: Select this when you experience picture flicker, which can happen when there is a clash with the frequency of the installed lighting.
- ESC : Select this to control the shutter speed automatically. If ESC is selected, the shutter speed is automatically controlled depending on the ambient illumination of the subject.
- MANUAL: You can control shutter speed manually. (1/60 ~ 1/120,000)



Notes

- When using a DC lens, set the shutter mode to A.FLK if color rolling occurs.
- When the SHUTTER is set to ESC after selecting Internal Synchronization Type, the picture may become unstable if the camera faces a bright fluorescent light. Therefore, take care when choosing the installation position.
- When the SHUTTER is set to MANUAL or A.FLK mode, SENS-UP will be disabled.

AGC (AUTO GAIN CONTROL) : The higher the gain level, the brighter the screen, but the higher the noise.

- OFF : Deactivates the AGC function.
- LOW : Allows automatic gain control from 5.3dB to 32dB.
- HIGH: Allows automatic gain control from 5.3dB to 37dB.

SENS-UP: When it is night or dark, the camera automatically detects the light level and maintains a clear picture if this mode is activated.

- OFF : Deactivates the SENS-UP function.
- AUTO : Activates the SENS-UP function.

RETURN:Select this to save the changes in the EXPOSURE menu and return to the SETUP menu.

Exposure- continued



Notes

- If you press the SET button in 'AUTO' mode, you can adjust brightness by increasing or decreasing the shutter speed. (x2 ~ x512)
- Note that the higher the zoom level, the brighter the screen, but the more likely it is that an after-image will appear.
- Although noise, spots, and whitish symptoms may occur in SENS-UP operation when the zoom level is increased, this is normal.

White Balance Control

Use the White Balance function to adjust the screen color.

1. When the SETUP menu screen is displayed, select 'WHITE BAL' by using the Up and Down buttons so that the arrow indicates 'WHITE BAL'.
2. Select a desired mode using the Left and Right buttons.

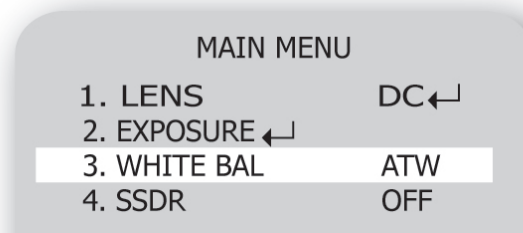

- ◆ Select one of the following 5 modes, as appropriate for your purpose.
- ⇒ **ATW** : Select this when the color temperature is between 1,700°K and 11,000°K.
- ⇒ **OUTDOOR** : Select this when the color temperature is between 1,700°K and 11,000°K (sodium light inclusion)
- ⇒ **INDOOR** : Select this when the color temperature is between 4,500°K and 8,500°K.
- ⇒ **MANUAL** : Select this to fine-tune White Balance manually. Set White Balance first by using the ATW or AWC mode. After that switch to MANUAL mode, fine-tune the White Balance and then press the SET button.
- ⇒ **AWC → SET** : To find the optimal luminance level for the current environment, point the camera towards a sheet of white paper and press the Function Setup switch. If the environment changes, readjust it.



Notes

- White Balance may not work properly under the following conditions. In this case select the AWC mode.
 - ① When the color temperature of the environment surrounding the subject is out of the control range (ie. clear sky or sunset).
 - ② When the ambient illumination of the subject is dim.
 - ③ If the camera is directed towards a fluorescent light or is installed in a place where illumination changes dramatically, the White Balance operation may become unstable.

SSDR (Super Dynamic Range)

SSDR illuminates darker areas of an image while retaining the same light level for brighter areas to even out the overall brightness of images with high contrast between bright and dark areas.

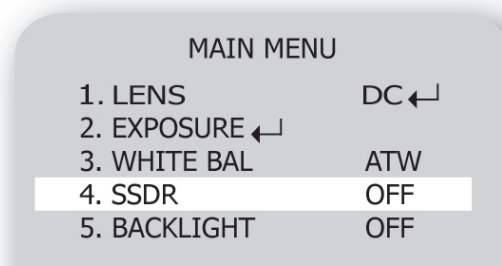

1. When the SETUP menu screen is displayed, select 'SSDR' by using the Up and Down buttons so that the arrow indicates 'SSDR'.
2. Turn on by using the Left/Right buttons and press SETUP to change the SSDR level in the sub-menu according to the contrast between bright and dark areas.

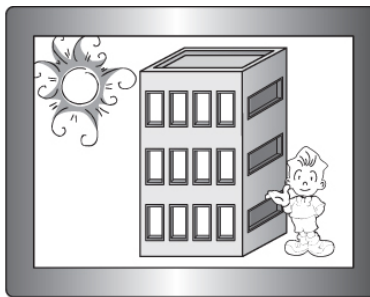

SSDR ON

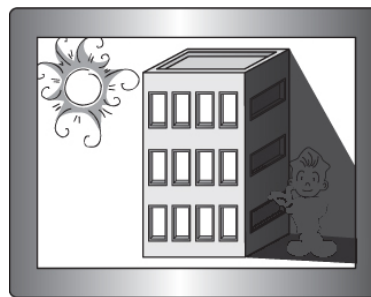

SSDR OFF

BLC (Back Light Compensation)

1. When the SETUP menu screen is displayed, select 'BACKLIGHT' by using the Up and Down buttons so that the arrow indicates 'BACKLIGHT'.

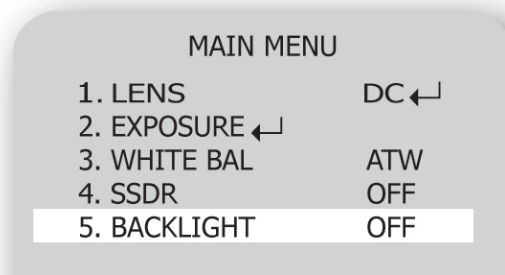

2. Select a desired mode using the Left and Right buttons depending on the camera purpose.

⇒ **BLC**: Enables a user to select a desired area on a picture and view that area more clearly.

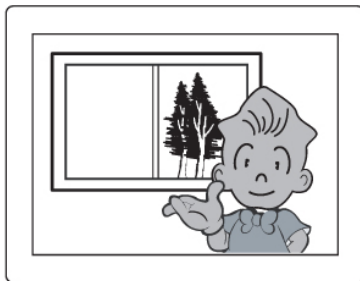

BLC ON

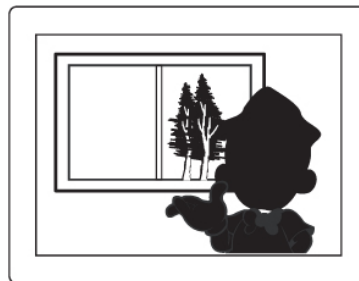

BLC OFF

⇒ **HLC (High Light Compensation)** : If the scene contains extremely bright light areas such as from car headlight, the light can mask out much of the on-screen detail. Use HLC feature to remove these exceptionally bright lit areas to allow detail such as car license plate number to become visible.

- LEVEL: Adjust level of the HLC function.
- LIMIT: Enable to change the operating condition.
- MASK COLOR/TONE : Change the color / brightness of the masking area.
(Black, Red, Blue, Cyan, Magenta)
- TOP/BOTTOM/LEFT/RIGHT : Adjust the area to be enhanced.

HLC MASKING AREA

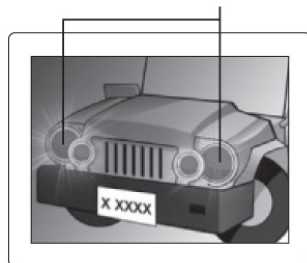

HLC ON

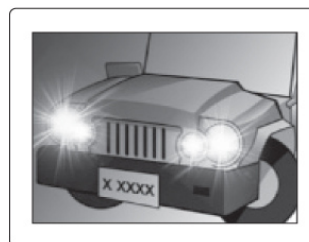

HLC OFF

⇒ **OFF** : Not being used.

HLC continued

3. Select a desired mode using the Left and Right buttons and press the SET button.

⇒ BLC : Select 'BLC' to adjust the area to be enhanced then adjust the level.

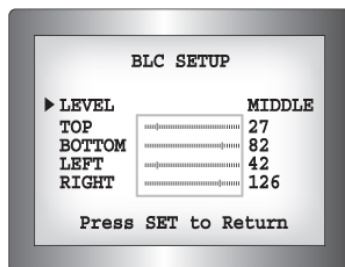

⇒ HLC : Enable the user to change the level limit, mask color/tone and area.

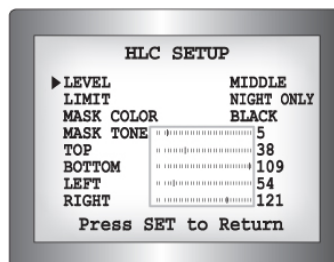

Notes

- For effective license plate observation, it needs minimum illumination and fast shutter speed more than 1/200sec.
- Because there can be a difference in the effectiveness of HLC according to the amount of light area in the screen, optimize the installation angle for the best HLC performance.
- When dark, the HLC is only activated when a bright light exceeding a specific size in NIGHT ONLY mode.
- The HLC is not activated in day light or when bright light is not present at night in NIGHT ONLY mode.

DNR3

This function reduces the background noise in a low luminance environment.

1. When the **SETUP** menu screen is displayed, select 'DNR' by using the Up and Down buttons so that the arrow indicates 'DNR'.

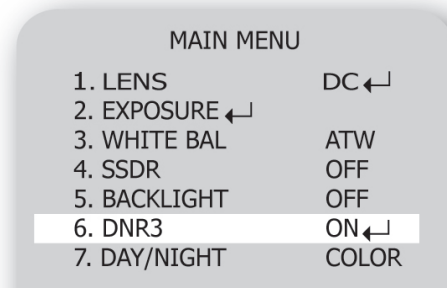

2. Select a desired mode using the Left and Right buttons.

➡ **OFF**: Deactivates DNR. Noise is not reduced.

➡ **ON** : Activates DNR so that noise is reduced.

3. Set the DNR mode to 'ON' and press the **SET** button. Then you can adjust the noise reduction level.



Notes

- You cannot set the DNR to 'ON' or 'OFF' when the AGC mode of the EXPOSURE menu is 'OFF'.
- When adjusting the noise reduction level in DNR mode, remember that the higher the level is set, the greater the reduction in noise level, as will the brightness of the image.

Day / Night

You can display pictures in color or black and white.

1. When the SETUP menu screen is displayed, select 'DAY/NIGHT' by using the Up and Down buttons so that the arrow indicates 'DAY/NIGHT'.

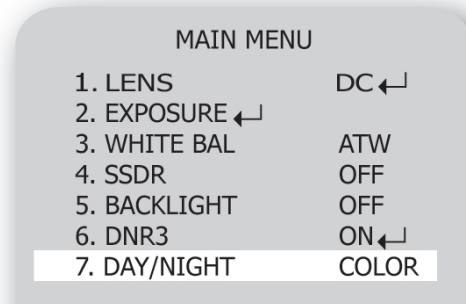

2. Select a desired mode using the Left and Right buttons according to the picture display you want.

- ⇒ **EXTERN** : This mode allows you to apply a desired filter to external signals.
- ⇒ **COLOR** : The picture is always displayed in color.
- ⇒ **B/W** : The picture is always displayed in black and white.
You can turn on or off the burst signal on B/W mode.
- ⇒ **AUTO** : The mode is switched to 'Color' in a normal environment, but switches to 'B/W' mode when ambient illumination is low. To set up the switching time for AUTO mode, press the SET button. You can turn on or off the burst signal on B/W mode.

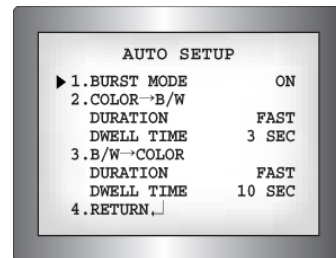

- DWELL TIME : You can select the duration time about changing the day/night mode.
(3s, 5s, 7s, 10s, 15s, 20s, 30s, 40s, 60s)



Notes

- When using a Video Auto Iris Lens, if you set the lens level to low, automatic switching between Color and Black & White may not occur.
- When AGC in the EXPOSURE menu is 'OFF', '---' mode operates as like selecting 'COLOR' mode, and 'AUTO' mode can not be selected.

SPECIAL

1. When the SETUP menu screen is displayed, select 'SPECIAL' by using the Up and Down buttons so that the arrow indicates 'SPECIAL'. Press SETUP to enter the 'SPECIAL' menu.

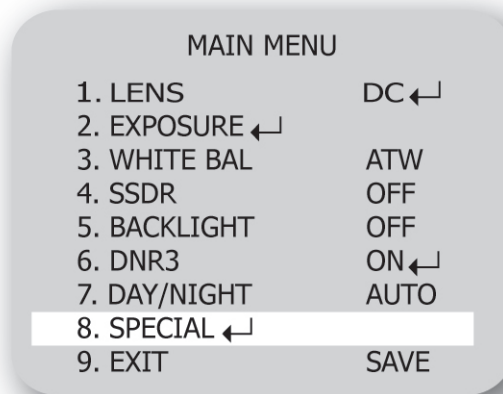

2. Select a desired mode using the Up and Down buttons.

➡ IMAGE ADJ:

1) When the SETUP menu screen is displayed, select 'IMAGE ADJ.' by using the Up and Down buttons so that the arrow indicates 'IMAGE ADJ.'. Press SETUP to enter 'IMAGE ADJ.'.

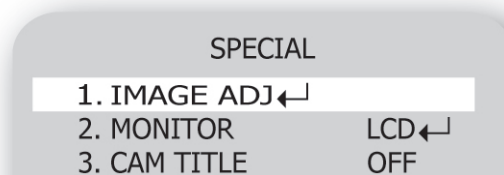

2) Select a desired mode using the Up and Down buttons.

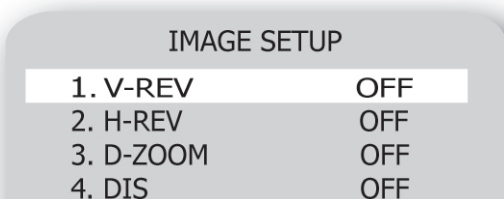

- **V-REV** : You can flip the picture vertically on the screen.
- **H-REV** : You can flip the picture horizontally on the screen.
- **D-ZOOM** : You can use a digital zoom of x1 ~ x16.
- **DIS (Digital Image Stabilizer)** : This function mitigates any picture movement due to external factors such as wind.



Notes

- As the DIS function uses the digital zoom the camera's resolution will decrease.
- DIS doesn't operate when background illumination is too low.
- DIS doesn't operate when object pattern is monotonic (ie. sky or white wall).

Image Adj. Continued

- **FONT COLOR :** You can change the OSD font color. (White, Yellow, Green, Red, Blue)
- **SHARPNESS:** As you increase this value, the picture outline becomes stronger and clearer. Adjust this value appropriately depending on the sharpness of the picture.
- **RETURN :** Select this to save the settings for the IMAGE ADJ. menu and to return to the SETUP menu.



Notes

- When the V-REV or H-REV mode is enabled, the text on the screen does not flip.
- If you increase the SHARPNESS level too high, the picture may become distorted or noise may appear.

⇒ **MONITOR :** Change the settings value of video that is appropriate to your monitor.

- LCD : Select this menu item when using a LCD monitor.
- CRT : Select this menu item when using a CRT monitor.
- USER : Use this menu item when using a monitor other than standard ones. You can change the gamma, PED level, and color gain in the sub menus.

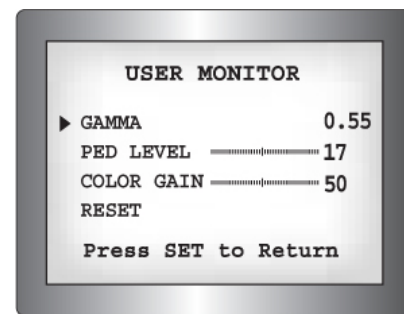

⇒ **CAM TITLE :** If you enter a title, the title will appear on the monitor.

- 1) If the SPECIAL menu screen is displayed, use the Up and Down buttons so that the arrow indicates 'CAM TITLE'.
- 2) Set it to 'ON' by using the Left and Right buttons.
- 3) Press the SET button.
- 4) Use the 4 direction buttons to move to a desired letter and select the letter by pressing the SET button. Repeat this to enter multiple letters. You can enter up to 15 letters.

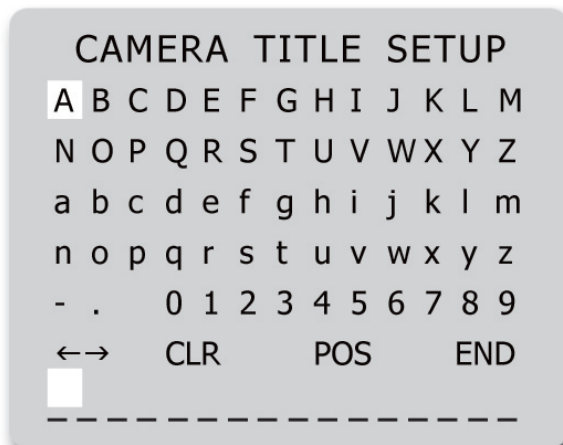

- 5) Enter a title, move the cursor to 'POS' and press the SET button. The entered title appears on the screen. Select the position to display the title on the screen by using the 4 direction buttons and press the SET button. When the position is determined, select 'END' and press the SET button to return to the SPECIAL menu.



Notes

- When the CAM TITLE menu is 'OFF', no title will be displayed on the monitor screen even if you enter one.
- Only English is available in this mode.
- If you move the cursor to CLR and press the SET button, all the letters are deleted. To edit a letter, change the cursor to the bottom left arrow and press the SET button. Move the cursor over the letter to be edited, move the cursor to the letter to be inserted and then press the SET button.

⇒ **SYNC** : In areas where the supply is at 60Hz, you can synchronize the output phase of multiple cameras using the power synchronization function (Line-Lock) without using a synchronization signal generator.

- INT: Internal Synchronization Type
- L/L: Power Synchronization Type, Line-lock

- Press the Function Setup switch.
- You can select a desired phase from 0 to 359 when select 'phase'.



Notes

- When using AC power at 60Hz frequency, you can use the L/L type synchronization.
- When the power is DC 12V, the SYNC menu is fixed to the 'INT' mode.

⇒ **MOTION DET** : You can monitor activity more efficient with this feature allowing you to observe movement of objects in 8 different areas on the screen, and the words 'MOTION DETECTED' appear on the screen when movement is detected..

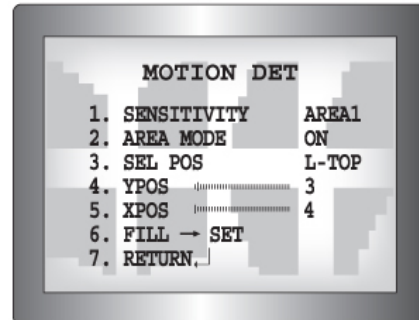

- 1) When the SPECIAL menu screen is displayed, press the Up and Down buttons so that the arrow indicates 'MOTION DET'.

Motion Detection- Continued

- 2) Set up the mode using the 4 direction buttons.
- SENSITIVITY : You can select up to 8 MD areas. When SENSITIVITY number is high, motion detection sensitivity is increased to recognize even small movement.
 - AREA MODE : Determines whether to use the MD area selected in SENSITIVITY.
 - SEL POS : Determines which of the 4 vertices of each MD area is to be used.
 - XPOS : Determines the coordinate of the horizontal axis for SEL POS.
 - YPOS : Determines the coordinate of the vertical axis for SEL POS.
 - FILL SET : Fills in a selected MD area. The color of filling is sequentially selected as brown, orange, blue, cyan, green, yellow, magenta and red.
 - RETURN : Select this to save the MOTION DET menu settings and return to the SPECIAL menu.

⇒ **PRIVACY** : Mask an area you want to hide on the screen.

- 1) When the SPECIAL menu screen is displayed, press the Up and Down buttons so that the arrow indicates 'PRIVACY'.

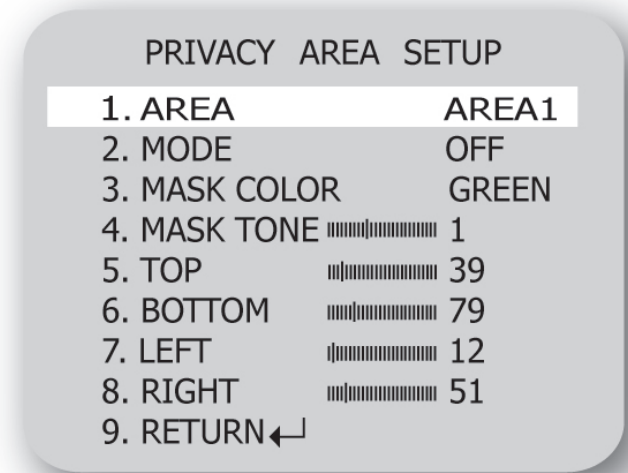

- 2) Set up the mode using the 4 direction buttons.
- AREA SEL : Select up to 12 PRIVACY areas.
 - MODE : Determines whether to use the area selected in the AREA SEL.
 - MASK COLOR : Determines area color. Select Green, Red, Blue, Black, White, Gray.
 - MASK TONE : Adjust the brightness of MASK COLOR.
 - TOP/BOTTOM/LEFT/RIGHT : Adjust the size and position of the selected area.
 - RETURN : Select this to save the PRIVACY menu settings and return to the SPECIAL menu.

⇒ **COMM ADJ (Communication Adjustment)** : This function sets up the camera communication status when controlling the camera through an external control device.

1) When the SPECIAL menu screen is displayed, press the Up and Down buttons so that the arrow indicates 'COMM ADJ'.

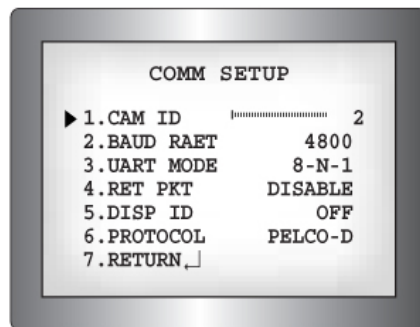

2) Set up the mode using the 4 direction buttons.

- CAM ID : Determines the camera's identification number (between 0 and 255).
- BAUD RATE : Select 2400/4800/9600/19200/38400/57600 bps.
- UART MODE : Select NONE, EVEN or ODD for the parity bits.
- RET PKT : Determines whether to send a command back to the controller device when a communication control command is sent to the camera.
- DISP ID : Display the camera title on the top left corner of the screen.
- PROTOCOL : STW(SPD), PELCO-D, PELCO-P, SEC, BOSCH, HONEY WELL, VICON, PANA.

⇒ **LANGUAGE** : You can select the menu language according to your requirements.

⇒ **RETURN** : Select this to save the SPECIAL menu settings and return to the MAIN SETUP menu.

Exit

Select a desired EXIT mode using the Left and Right buttons depending on the camera purpose.

- SAVE : Save the current settings and exit the MAIN SETUP menu.
- NOT SAVE : Do not save the current settings and exit the MAIN SETUP menu.
- RESET: Resets the camera settings to the factory defaults. Language and Monitor settings are not initialized.

Troubleshooting

If you have trouble operating your device, refer to the following table. If the guidelines do not enable you to solve the problem, contact Clinton Electronics Technical Support at 1-800-549-6393 or 815-633-1444.

Problem	Solution
Nothing appears on the screen.	<ul style="list-style-type: none"> • Check the power connection. • Check the video signal line connection. • Check the Brightness of Auto Iris lens. • Press the POWER button on your remote control. • Check to ensure the proper voltage is applied to the display. In the case of long runs or small wire size, there may be a significant voltage drop to the display resulting in insufficient voltage to properly power the display. Consult your power supply manual to determine if the voltage can be increased to compensate.
The video image is not clear.	<ul style="list-style-type: none"> • Check if the screen and lens are clean. Clean with a clean cloth. • Adjust the contrast feature of the monitor. • Make sure that the screen is not exposed directly to a bright light • Enter the OSD settings of the display with the remote control. Go to the SHARPNESS setting and increase the value. <p>NOTE: Pixelization in low light conditions is considered normal.</p>
The screen is dark.	<ul style="list-style-type: none"> • Adjust the contrast feature of the monitor. • If you have an intermediate device, set the 75Ω/Hi-z properly, and check the terminals. • Adjust the brightness level of the lens in the camera OSD menu.
There is a problem with the camera operation. The camera surface is too hot and black stripes appear on the screen.	<ul style="list-style-type: none"> • Check if an appropriate power source to the camera complies with the manufacturer's standard requirement, or if the voltage keeps changing.
No Audio	<ul style="list-style-type: none"> • Make sure the mute function is not activated. • Turn up the volume. • If using chime sound, make sure audio output is set to "Chime". • If using SD-Card audio, make sure it is a supported audio format.

Troubleshooting

Problem	Solution
The MOTION DETECTION function is not working.	<ul style="list-style-type: none">• Check if 'MOTION DETECTION' mode is turned on.• Check if the MD LEVEL is too low.• Check the setting of the MD AREA.
Colors are not quite right.	<ul style="list-style-type: none">• Check the 'WHITE BAL' setting.
The screen is flickering.	<ul style="list-style-type: none">• Check if the camera is facing directly into sunlight or fluorescent light.
L/L mode isn't able to be selected.	<ul style="list-style-type: none">• Have you connected your camera to DC power source? Connect it to AC power source.
L/L mode is not available.	<ul style="list-style-type: none">• When using DC 12V input power, 'SYNC' mode is fixed to 'INT'.
COLOR (DAY & NIGHT) mode is not working.	<ul style="list-style-type: none">• Check if the AGC menu is set to the OFF position.
SENS-UP function is not working.	<ul style="list-style-type: none">• Check if the AGC menu is set to the OFF position.• Check the limit of SENS-UP AUTO mode.



CLINTON Electronics

CLINTON Electronics

CLINTON Electronics
6701 Clinton Road
Loves Park, IL 61111

1.800.447.3306 **Sales**
1.800.549.6393 **Support**
1.815.633.8712 **Fax**

www.clintonelectronics.com

v.05.20.11