

LCD5.5 5" CCTV Lcd Test Monitor



INFO:

- 640 x 480 Resolution
- 4:3 Aspect Ratio
- 250 nit Brightness
- 400:1 Contrast Ratio
- 1 BNC Input / 1 RCA Input
- Plastic Bezel
- Carry Bag Included
- Neck & Wrist Strap Included
- Lithium Ion Battery Pack & Charger Included

DIMENSIONS:

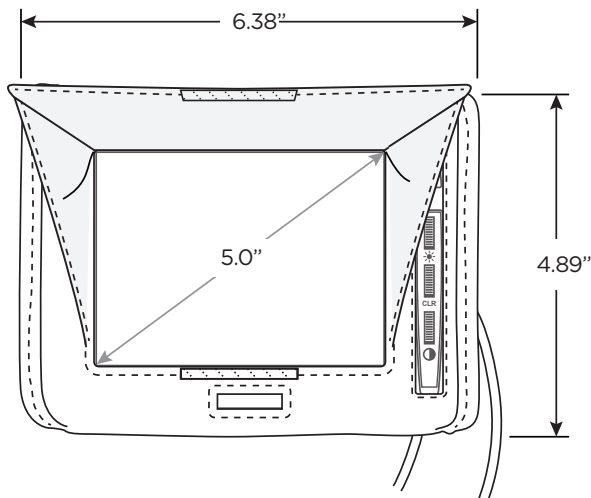

SPECIFICATIONS:

LCD Panel	5"
Resolution	640 x 480
Control	OSD Control Function
LCD Profile Ratio	4:3
Display Colors	16M
Brightness	250 nit
Contrast Ratio	400:1
Viewing Angle	25/45/45/45
Response Time	12ms
In / Output Impedance	75Ω / Auto Terminal Output
Video Input / Output	BNC Input
Power Consumption	6 Watts
Power Requirement	Lithium Ion Battery / DC12V
Operating Temperature	35°F - 100°F
Dimensions	6.38" (W) x 4.89" (H) x 2.95" (D) 162.052mm (W) x 124.206mm (H) x 74.93mm (D)
Weight (with battery)	1.4 lbs / 635.029g

